

To Access The Message Center Menu:

On the STATUS screen, select **Menu**.

On the MAIN MENU screen, select **Message Center**.

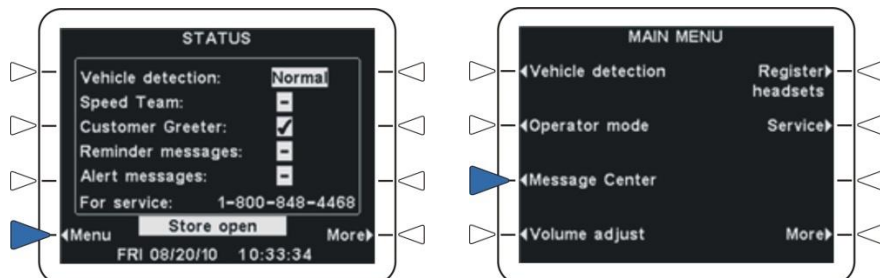

The MESSAGE CENTER MENU is the starting point for all Message Center activity.

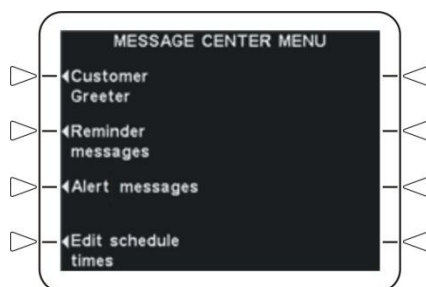

From the MESSAGE CENTER MENU, you can do the following:

(Select links below for detailed instructions)

- [**Review/Record messages**](#)
- [**Rename messages**](#)
- [**Turn messages on/off**](#)
- [**Schedule messages**](#) (days & time periods)
- [**Set locations**](#) for messages to be heard
- [**Set delay**](#) before messages play (Customer Greeter or Alert)
- [**Set messages to repeat**](#) (Reminder or Alert)
- [**Set message priorities**](#) (Reminder or Alert)
- [**Edit schedule times**](#) (up to 12 time periods)

NOTE: Your screens may be slightly different than the ones in this operation guide. This guide is for single-lane operations. For dual-lanes, additional screens will appear, providing options to make settings for either lane.

If you need help, call or fax HME Technical Support at the numbers below.

To Review/Record A Message:

1. Select **Menu** on the STATUS screen, and **Message Center** on the MAIN MENU, and then select the type of message you want to review/record from the MESSAGE CENTER MENU.

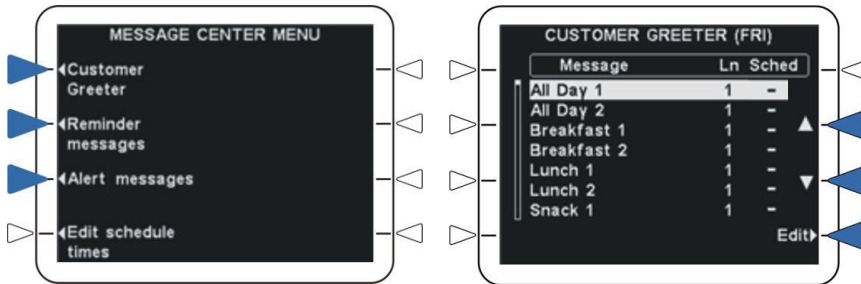

2. Select the up ▲ and down ▼ arrows to highlight the message you want to review and/or record, and then select **Edit**.

3. On the EDIT (type of message) screen, select **Review/Record**.

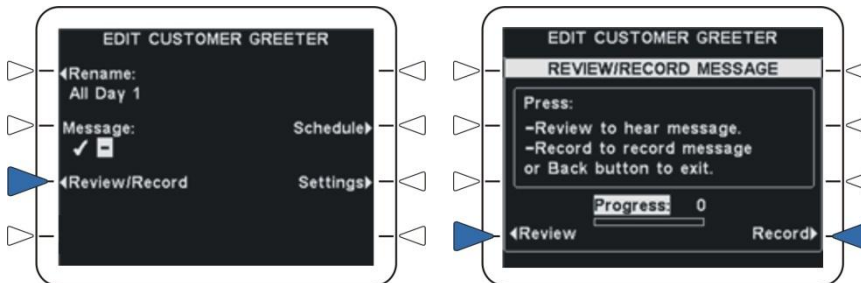

4. If you want to hear the current message, select **Review**, or, if you would like to record a new message, select **Record**.



5. To start recording, press and hold the **B** button on your headset or belt pac and speak into the headset microphone. You have 16 seconds recording time for Customer Greeter messages, 10 seconds for Reminders and Alerts. The Progress line indicates recording time passing.

6. When you finish recording, release the **B** button.

7. To listen to the new message, select **Review**.



Back

To return to previous screens, press the **Back** button below the screen.

To Rename A Message:

1. Select **Menu** on the STATUS screen, and **Message Center** on the MAIN MENU, and then select the type of message you want to rename from the MESSAGE CENTER MENU.

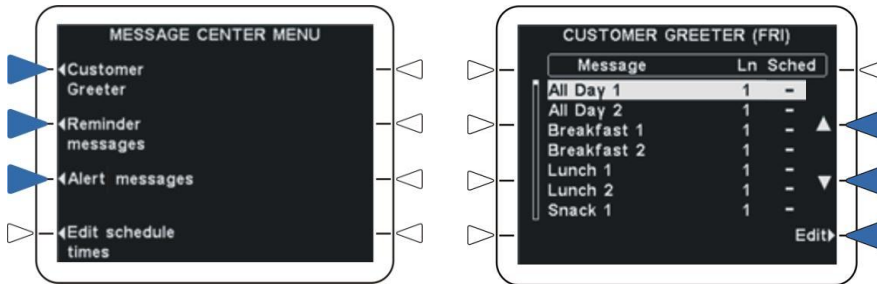

2. Select the up ▲ and down ▼ arrows to highlight the message you want to rename, and then select **Edit**.

3. Select **Rename** from the EDIT (type of message) screen.

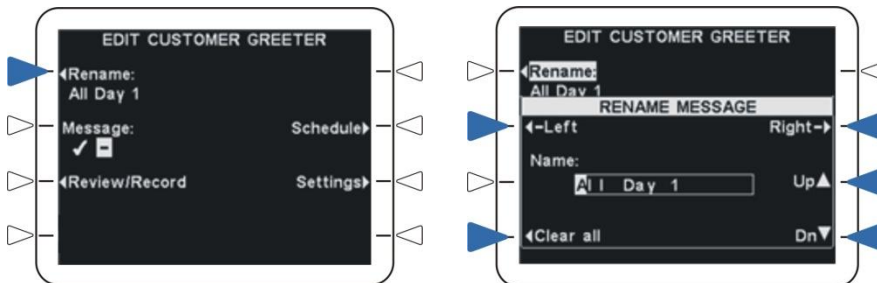

Back

To save this setting, press the **Back** button below the screen.

4. Select the <Left and Right> arrows to highlight a character in the Name field that you want to change. Select the Up ▲ and Dn ▼ arrows to scroll through upper and lower case letters, numbers and blank space. If you want to begin with a blank Name field, select **Clear all** and then use the <Left, Right>, Up ▲ and Dn ▼ arrows to enter a new name.

To Turn A Message On/Off:

NOTE: When a message is turned on ✓, it will only be played during a scheduled time period when one of the following events occurs. A Customer Greeter message will be played when a drive-thru customer arrives. A Reminder message will be played at the beginning of a scheduled time period. An Alert message will be played when an alert situation occurs.

1. Select **Menu** on the STATUS screen, and **Message Center** on the MAIN MENU, and then select the type of message you want to turn on or off from the MESSAGE CENTER MENU.

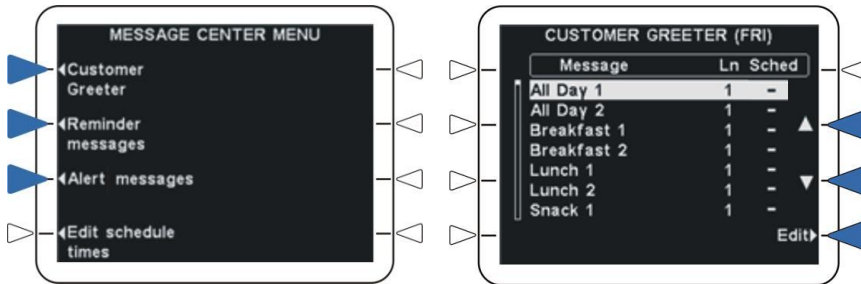

2. Select the up ▲ and down ▼ arrows to highlight the message you want to turn on/off, and then select **Edit**.

3. **If you want to turn the message on/off during all scheduled time periods,** on the EDIT (type of message) screen, select **Message** to highlight ✓ (on) or - (off).

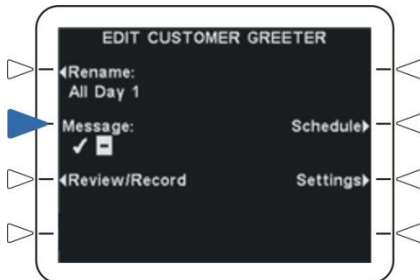

NOTE: If the message is turned on ✓, it will be played only in the time period(s) when it is scheduled.

Back

➔ To save this setting, press the **Back** button below the screen.

To Schedule A Message To Be Played Or Not Played During Selected Time Periods:

NOTE: A message will only be played if it is turned on, during a scheduled time period when one of the following events occurs. A Customer Greeter message will be played when a drive-thru customer arrives. A Reminder message will be played at the beginning of a scheduled time period. An Alert message will be played when an alert situation occurs.

1. Select **Menu** on the STATUS screen, and **Message Center** on the MAIN MENU, and then select the type of message you want to schedule from the MESSAGE CENTER MENU.

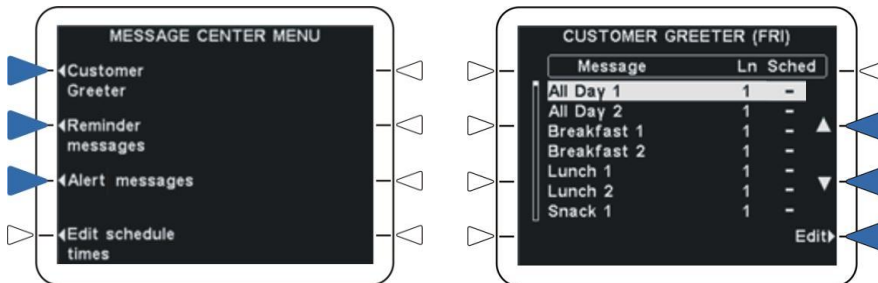

2. Select the up ▲ and down ▼ arrows to highlight the message, and then select **Edit**.

3. Select **Schedule** from the EDIT (type of message) screen.

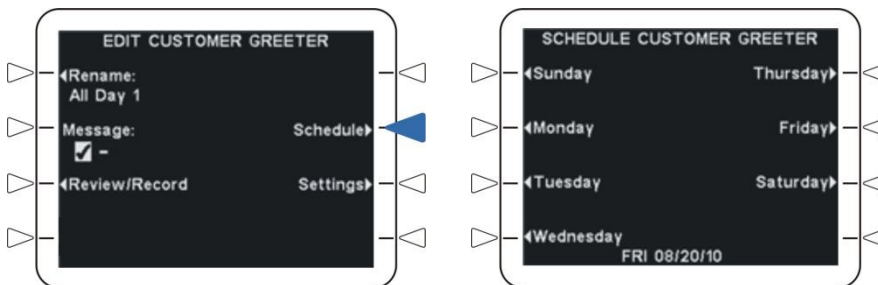

4. Select the weekday for which you would like to set the message schedule.

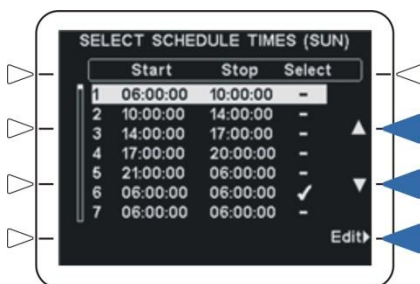

5. Select the up ▲ and down ▼ arrows to highlight the desired time period for the message to be played or not played during the selected day, and then select **Edit**.

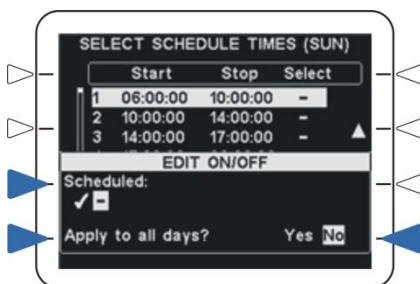

6. To turn the message on or off during this time period, select **Scheduled** to highlight ✓ (on) or - (off).

NOTE: For a message to be triggered to play during a scheduled time period, it must also be turned on ✓.

7. If you want this setting to apply to all days, select **Apply to all days?** and highlight **Yes**. If **No** is highlighted, this setting will apply only to the selected day.

Back

To save this setting, press the **Back** button below the screen.

To Set Locations Where A Message Will Be Heard:

1. Select **Menu** on the STATUS screen, and **Message Center** on the MAIN MENU, and then select the type of message whose location you want to set from the MESSAGE CENTER MENU.

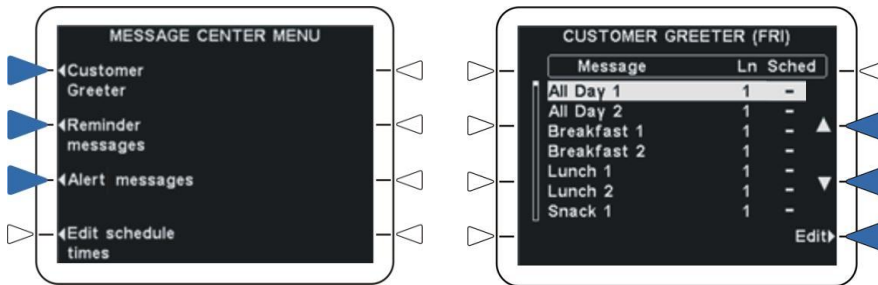

2. Select the up ▲ and down ▼ arrows to highlight the message, and then select **Edit**.

3. Select **Settings** from the EDIT (type of message) screen.

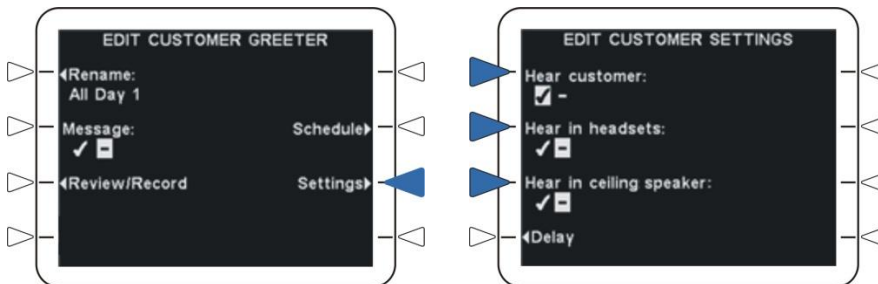

4. Select a location where you would like the message to be heard or not heard, and highlight ✓ (on) or - (off) for that location.

5. If you want **Reminder/Alert messages to be heard only in selected headsets**, on the EDIT REMINDER SETTINGS or EDIT ALERT SETTINGS screen, select **Headsets**.

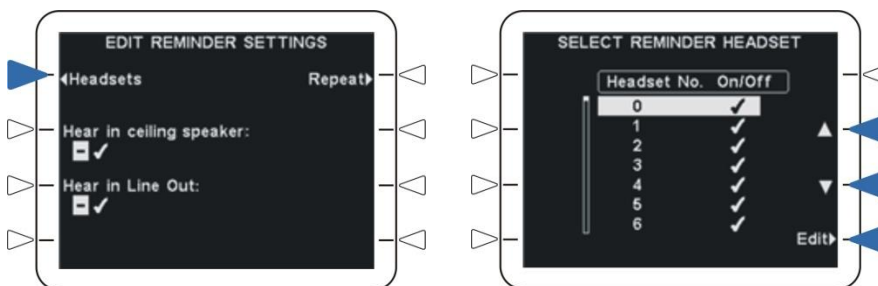

6. Use the up ▲ and down ▼ arrows to select a headset number at which you want the message to be heard ✓ (on) or not heard - (off), and then select **Edit**.

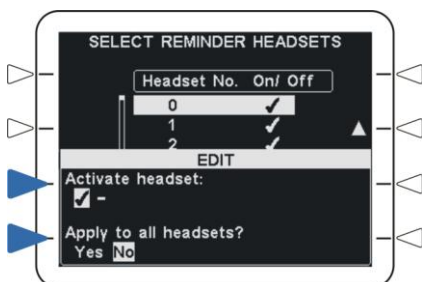

7. For the message to be heard in this headset, select **Activate headset** to highlight ✓ (on). If you do not want the message heard in this headset, highlight - (off).

8. If you want this setting to apply to all headsets, select **Apply to all headsets?** and highlight **Yes**. If **No** is highlighted, this setting will apply only to the selected headset.

Back → To save this setting, press the **Back** button below the screen.

To Set A Delayed Or Repeating Message:

1. Select **Menu** on the STATUS screen, and **Message Center** on the MAIN MENU, and then on the MESSAGE CENTER MENU, select the type message you want to delay or repeat.

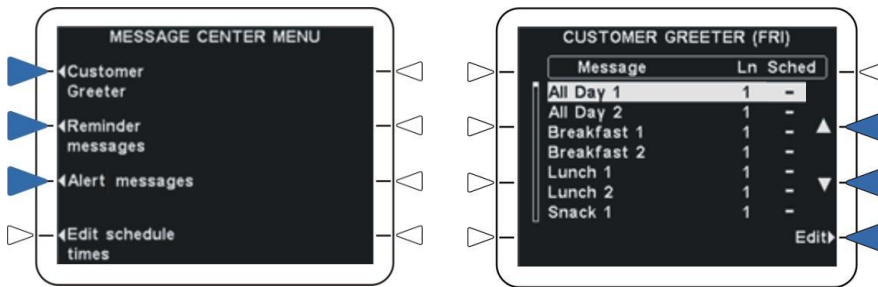

2. Select the up ▲ and down ▼ arrows to highlight the message, and then select **Edit**.



3. Select **Settings** from the EDIT (type of message) screen.

To Set Customer Greeter or Alert messages to be delayed from the time a message is triggered until it is played;

1. On the EDIT CUSTOMER SETTINGS or EDIT ALERT SETTINGS screen, select **Delay**.

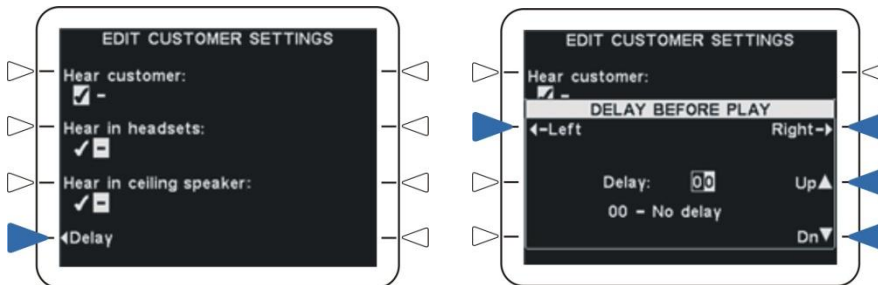

2. To set the number of seconds delay, select the <-Left and Right-> arrows to highlight the number in the Delay field that you want to change. Select the Up▲ and Dn▼ arrows for higher or lower numbers.

Back ← To save this setting, press the **Back** button below the screen.

To set Reminder or Alert messages to be repeated;

1. On the EDIT REMINDER SETTINGS or EDIT ALERT SETTINGS screen, select **Repeat**.

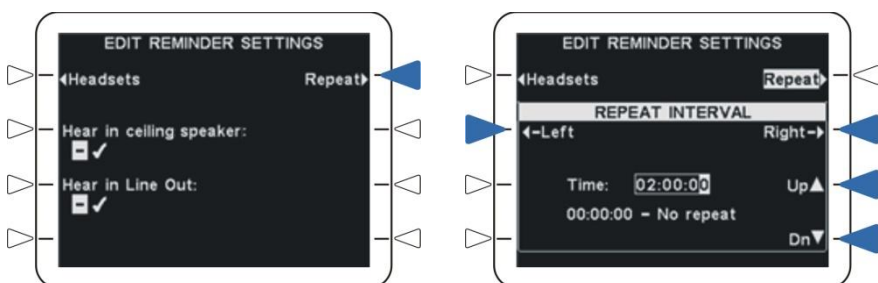

2. To set the time interval between repeats, select the <-Left and Right-> arrows to highlight the numeral in the Time field that you want to change (HH:MM:SS, where HH = hours, MM = minutes and SS = seconds). Select the Up▲ and Dn▼ arrows for higher or lower numbers. If you do not want the message to repeat, set all zeros in the Time field.

To save this setting, press the **Back** button below the screen. → **Back**

To Set Message Priority:

High or low priority can be set for Reminders (and for Alerts in some Message Centers). If a crew member is communicating with a customer when a low priority message is scheduled to play, the message will be cancelled. If set with high priority, the message will play after communication with the customer has been completed.

1. Select **Menu** on the STATUS screen, and **Message Center** on the MAIN MENU, and then select the type of message you want to prioritize from the MESSAGE CENTER MENU.

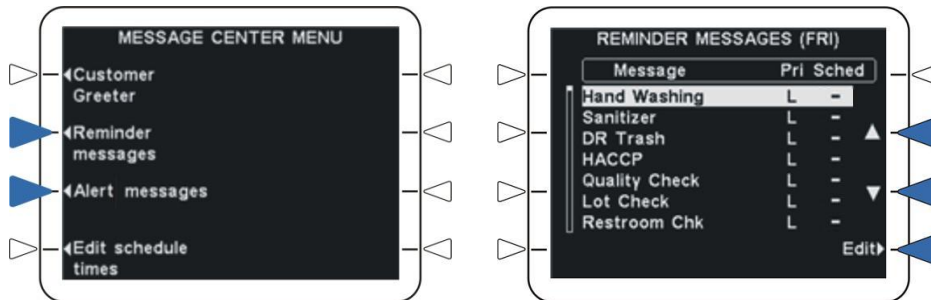

2. Select the up ▲ and down ▼ arrows to highlight the message, and then select **Edit**.

3. Select **Priority** from the EDIT (type of message) screen to highlight **High** or **Low**.



Back

To save this setting, press the Back button below the screen.

To Edit Schedule Times:

1. Select **Menu** on the STATUS screen, and **Message Center** on the MAIN MENU, and then select **Edit schedule times** on the MESSAGE CENTER MENU.



NOTE: Up to 12 time periods can be scheduled, which should include all required periods for every day of the week. Time periods can be overlapping, or can have gaps between them. Messages can be set to play or not to play during any time period.

CAUTION: Changing the Start time for any time period will change the time when any message(s) scheduled for that period will be played.

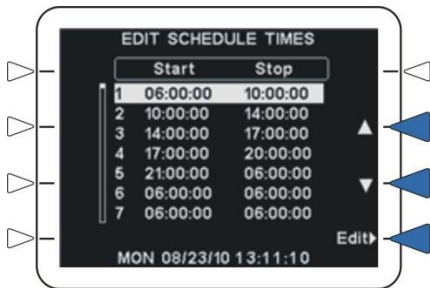

2. Select the up ▲ and down ▼ arrows to highlight the time period you want to set or change. You can continue moving the highlighted line down past 7.

3. When the desired time period is highlighted, select **Edit**.

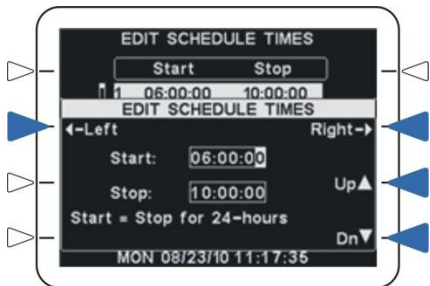

4. Select the **←Left** and **Right→** arrows to highlight a number in the Start or Stop field that you want to change. As the highlight passes the end of either field, it will move into the other. Select the **Up▲** and **Dn▼** arrows for higher or lower numbers.

Back

To save this setting, press the **Back** button below the screen.